

VACUUM TANKER

BROCHURE





Page 5
SA-S Single Axle - Standard



Page 10
SA-R Single Axle - Recessed



Page 20
TD-S Tandem - Standard



Page 28
TS-R Tandem Semi - Recessed



Page 34
TD-R Tandem - Recessed



Page 44
TRI-S Triple - Standard



Page 50
TRI-SR Triple - Semi Recessed

MODELS

- 5 SA-S
- 10 SA-R
- 20 TD-S
- 28 TS-R
- 34 TD-R
- 44 TRI-S
- 50 TRI-SR

OPTIONS

- 54 Jurop
- 57 Spread anywhere, anytime
- 58 Umbilical spreading
- 60 Umbilical connections
- 61 Level indicators, filling up
- 62 Storage and convenience
- 64 Be safe, be seen
- 65 Auto-fill and turbo-fill
- 66 Loading and unloading
- 68 Safety, comfort and control

TYRES

- 70 All Models

APPLICATORS

- 72 HiSpec Dribble Bar
- 76 HiSpec Trail-S
- 84 HiSpec Macerator
- 86 Technical
- 91 Sales
- 91 Contact





Our Story

Established in 1988, HiSpec Engineering Ltd is a family-owned and run company based in Carlow, Ireland. Since the company's inception, we have grown progressively as a manufacturer and supplier of top quality machinery.

Our core activity is centred on the design and manufacturing of innovative and reliable machinery for use throughout the agricultural sector. We are a company that is proud of the dependable and honest reputation we have built. We aim to continue a sustainable business that will benefit national and international communities.

HiSpec Engineering has invested heavily in our production facilities in order to provide our customers with the highest quality products. We have established a strong core dealer network throughout Ireland and the UK. We also manufacture and distribute agricultural machines to various countries around the world.

We are focused on improving our products and we are always looking to establish greater efficiencies to ensure that HiSpec maintains its reputation as a market leader in manufacturing high quality agricultural products.

Yours Sincerely,

The Nolan Family



Browse our Tanker Range



SA-S

Single Axle- Standard

- 800 SA-S
- 1150 SA-S
- 1350 SA-S
- 1600 SA-S
- 2000 SA-S

Non recessed single axle tankers featuring a 9000 litre Jurop pump as standard and an agricultural axle. Suited for smaller farms, capacities from 800 to 2000 gallons.

SA-R

Single Axle- Recessed

- 1350 SA-R
- 1600 SA-R
- 2000 SA-R
- 2300 SA-R
- 2600 SA-R
- 3000 SA-R

Single axle recessed tankers with large diameter wheels, ideal for farmers and contractors alike.

Capacities from 1350 to 3000 gallons. Sprung drawbar and commercial axle as standard.

TD-S

Tandem- Standard

- 3000 TD-S
- 3500 TD-S
- 4000 TD-S

Non recessed tandem axle with straight mudguards. Standard on a parabolic commercial axle with 560/60 R22.5 tyres.

Capacities from 3000 to 4000 gallons. Jurop 11000 litre pump fitted as standard.

Optional on 26.5 tyres.

TS-R

Tandem Semi- Recessed

- 3000 TS-R
- 3500 TS-R
- 4000 TS-R

Semi-Recessed tandem axle to lower overall height. Chassis is narrowed to reduce width when compared to TD-S.

Capacities from 3000 to 4000 gallons. Standard on a parabolic commercial axle with 710/50 R26.5 tyres.

A Jurop 11000 litre pump fitted as standard.

TD-R

Tandem- Recessed

- 3000 TD-R
- 3500 TD-R
- 4000 TD-R

Fully recessed tandem on 750/60 R30.5 tyres for large footprint.

Capacities from 3000 to 4000 gallons. Standard on a parabolic commercial axle, with large diameter tyres for low rolling resistance.

A Jurop 11000 litre pump fitted as standard.

Applicators



TRI-S

Triple- Standard

- 4000 TRI-S
- 4500 TRI-S
- 5000 TRI-S

Non recessed triple axle tanker on large parabolic axle complete with rear steering.

Capacities from 4000 to 5000 gallons. Standard on 560/60 R22.5 tyres, but can be fitted on 26.5 rims.

Ideal for ferrying large volumes.

TRI-SR

Triple- Semi Recessed

- 5000 TRI-SR
- 5500 TRI-SR
- 6000 TRI-SR

Semi-recessed triple axle tankers on 710/50 R26.5 tyres as standard.

Semi recess allows the tanker to be lower and narrower for road work. Ideal for large volume haulage.

Capacities from 5000 to 6000 gallons. Commercial axle complete with rear steering as standard.

D-B

Dribble Bar

- 7.5 D-B
- 9.0 D-B
- 10.5 D-B

Chassis mounted dribble bar from 7.5 metres upwards.

HiSpec macerator as standard, fully galvanised and complete with break back wings.

T-S

Trailing Shoe

- 7.5 T-S
- 9.0 T-S
- 10.5 T-S

Chassis mounted trailing shoe complete with folding ends and HiSpec macerator.

Available in 7.5, 9 and 10.5 metre working widths

SA-S

SA-S Single Axle- Standard

SA-S offers a basic specification to meet the needs of small farms. Capacity ranges from 800 to 2000 gallons. SA-S feature non-recessed wheels with an agricultural axle making it ideally paired with smaller HP tractors.

The barrel is manufactured in 6mm steel and fully supported to the chassis below. The chassis is complete with an A-frame drawbar for tight turning.

A powerful 9000 litre Jurop pump is fitted for prompt filling. The pump is protected with a secondary syphon as standard. Tyres of choice are 550/60 - 22.5 due to excellent flotation. Alternatively, 540/70 R24 are available with a tractor grip for improved stability on sloped ground.





1600

HIT SPEC





SA-S models are fitted on an eight stud agricultural axle with hydraulic brakes. LED road-lights and mudguards* ensure that you are ready for the road. The smaller capacities and flotation wheels allow SA-S to float easily over land.

All SA-S are finished with a premium paint job. The tanker is shot-blasted prior to application of our durable red paint finish. The rear manhole is galvanised and suitable for mounting of a dribble bar if required.

** mudguards standard from 1350 SA-S upwards*

SA-R





Large capacity and an easy pull

SA-R Single Axle- Recessed

SA-R are single axle recessed tankers for farmers and contractors alike. Manufactured in 6mm British steel with capacities from 1350 to 3000 gallons. SA-R tankers have collared dished ends and internal ribs for a strong build.

Our full length folded chassis is unique to HiSpec and supports the barrel along its entire length; reducing stress and distributing weight evenly. SA-R tankers are also fitted with internal baffles to prevent slurry surge. A sprung drawbar and swivel hitch ensure smooth and comfortable towing.

SA-R feature large, recessed Alliance tyres to cover a wide footprint. Alliance tyres allow for an easy pull of large capacities. SA-R up to 2300 SA-R are fitted on 750/70 R26 Alliance (28.1). The larger 2600 SA-R is fitted with a heavy-duty 800/65 R32 Alliance (30.5), while the 3000 SA-R is complete with a superior strength 750/60 R30.5 Alliance.

Also unique to HiSpec is our stepped axle, which is standard up to 2300 SA-R and lowers the overall height of the tanker. This stepped axle aids stability and comfort.

The 2600 and 3000 SA-R are fitted on a specially lowered chassis and a straight commercial axle for extra carrying capacity while still maintaining a low overall height.





*Stepped Commercial Axle
standard up to 2300 SA-R*

Stepped Axle

HiSpec use a stepped commercial (10 stud) axle beam on our SA-R range up to 2300 gallons. The stepped axle offers a lower centre of gravity immediately improving handling and stability. The stepped axle lowers the rear of the tanker approximately 125mm, while also maintaining a full chassis the entire length of the barrel. 420x180 commercial brakes offer high braking efficiency suitable for all applications.

The 2600 and 3000 SA-R are fitted on straight commercial (10 stud) axles for increased carrying capacity. These straight axles are fitted with large commercial hydraulic brakes for maximum stopping power.





Jurop Pumps

Since 1976, Jurop pumps are manufactured in a state-of-the-art factory in Italy. For 45 years Jurop have been recognised as the fastest and most powerful vacuum pump available.

PTO driven as standard, the PN Series is the fastest method to fill or empty your tanker. The PN Series use sliding vanes to create vacuum or pressure inside the tank. A manual pump changeover is fitted as standard between pressure and vacuum. The PN Series are air cooled and use forced lubrication for minimal maintenance.

Jurop PN 84	9000 litre	up to 2000 gallon
Jurop PN 106	11000 litre	2300 gallon upward
Jurop PN 140	14000 litre	optional

Options include:

*Silencer
Walterscheid wide angle PTO
Hydraulic changeover
Hydraulic drive pump*



Jurop

SA-R





Swivel Hitch and Suspension

HiSpec use a 50mm swivel ring hitch as standard for SA-R models. The swivel hitch allows the tanker to follow the tractor easier over uneven terrain.

The swivel hitch is fitted via a bushing onto the drawbar, which makes replacement easier. A greasing point is provided to increase working life.



HiSpec use load sensing coil springs on SA-R to provide suspension and comfort. The capacity of the coils are matched to the tanker and its laden weight.

The coils are placed at the front of the barrel where most of the downward pressure is felt. The drawbar is also heavily reinforced to ensure that any loading is safely transferred to the swivel hitch.







Alliance Tyres



High performing Alliance tyres are fitted on all SA-R. Alliance Tyre Group (ATG) is a subsidiary of Yokohama Group. ATG has a presence in over 120 countries across six continents. HiSpec is partnered with Alliance to maintain a high quality finish across our SA-R range. The tyres are the only part of the your tanker in contact with the ground so it is imperative that you have the correct tyre to suit your job.



750/70 R26 Alliance
(28.1)
up to 2300 SA-R
Load Index 158 A8

The 750/70 R26 Alliance is the ideal tyre for a farmer looking for a wide footprint and a low rolling resistance.

Ideal for farmer's own use.

Standard up to 2300 SA-R.



800/65 R32 Alliance
(30.5)
2600 SA-R
Load Index 181 A8

800/65 R32 Alliance possesses a wider footprint and increased height to reduce ground pressure and increase carrying capacity.

Load index of 181 A8 equates to a capacity of 8,250kgs per tyre at 40kmph.

Standard on 2600 SA-R and optional for other sizes.



750/60 R30.5 Alliance
3000 SA-R
Load Index 181 D

750/60 R30.5 Alliance tyres are fitted to the 3000 SA-R to cater for increased weight and speed demands.

A load index of 181 D ensures top performance up to 65km/h. These tyres have a flatter pattern making them ideal for mixed road and field use.

TD-S //





TD-S Tankers Tandem Axle- Standard

TD-S are non-recessed tandem tankers fitted on 22.5 or 26.5 tyres. TD-S offers greater carrying capacities than single axle tankers. With a demand for improved efficiency, contractors are turning towards tandem models. TD-S range from 3000 to 4000 gallons.

TD-S are packed with features including a sprung drawbar, swivel ring hitch and a high-speed parabolic axle. Rear steering as standard and reinforced internal baffles ensure a smooth ride.



Parabolic under-slung tandem axle

The parabolic axle is welded along the entire chassis for maximum support. The parabolic is particularly suited to intensive use as stresses and strains are transmitted over a greater distance than a conventional bogie. The suspension is under-slung to reduce height and increase stability as you travel from one job to the next.

TD-S



Rear steering for manoeuvrability

TD-S are supplied with rear steering for manoeuvrability. The steering can be opened in forward direction to allow the tanker to follow easily and reduce damage on headlands.

To reverse, the rear wheels are hydraulically 'locked'. This straightens the wheels and allows the operator to reverse with ease. The steering should always be 'locked' for road transport.

For safety, all TD-S are fitted with 420x180 hydraulic brakes. Air brakes can be added for increased stopping power. An axle greasing bank can also be fitted to reduce maintenance tasks.

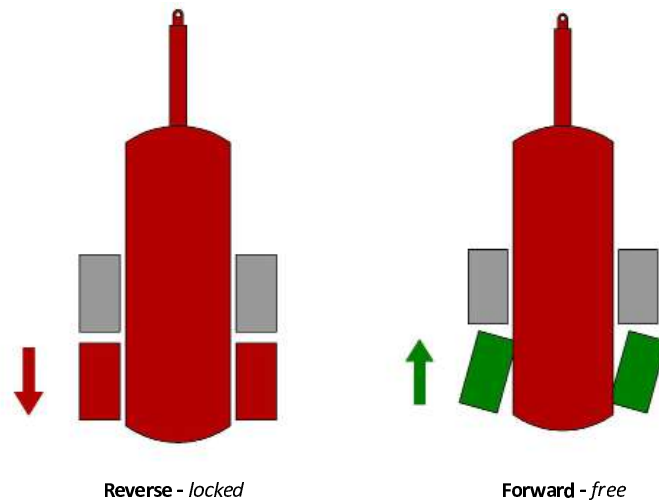

Forced Steering

It is also possible to fit 'forced' steering as an option. Forced steering is teamed up with a spoon hitch to provide the safest and most comfortable setup. Forced steering uses a ram on the drawbar to 'pressurise' the rear axle to turn. This has the added benefit of being able to reverse easier around corners and tight farmyards.



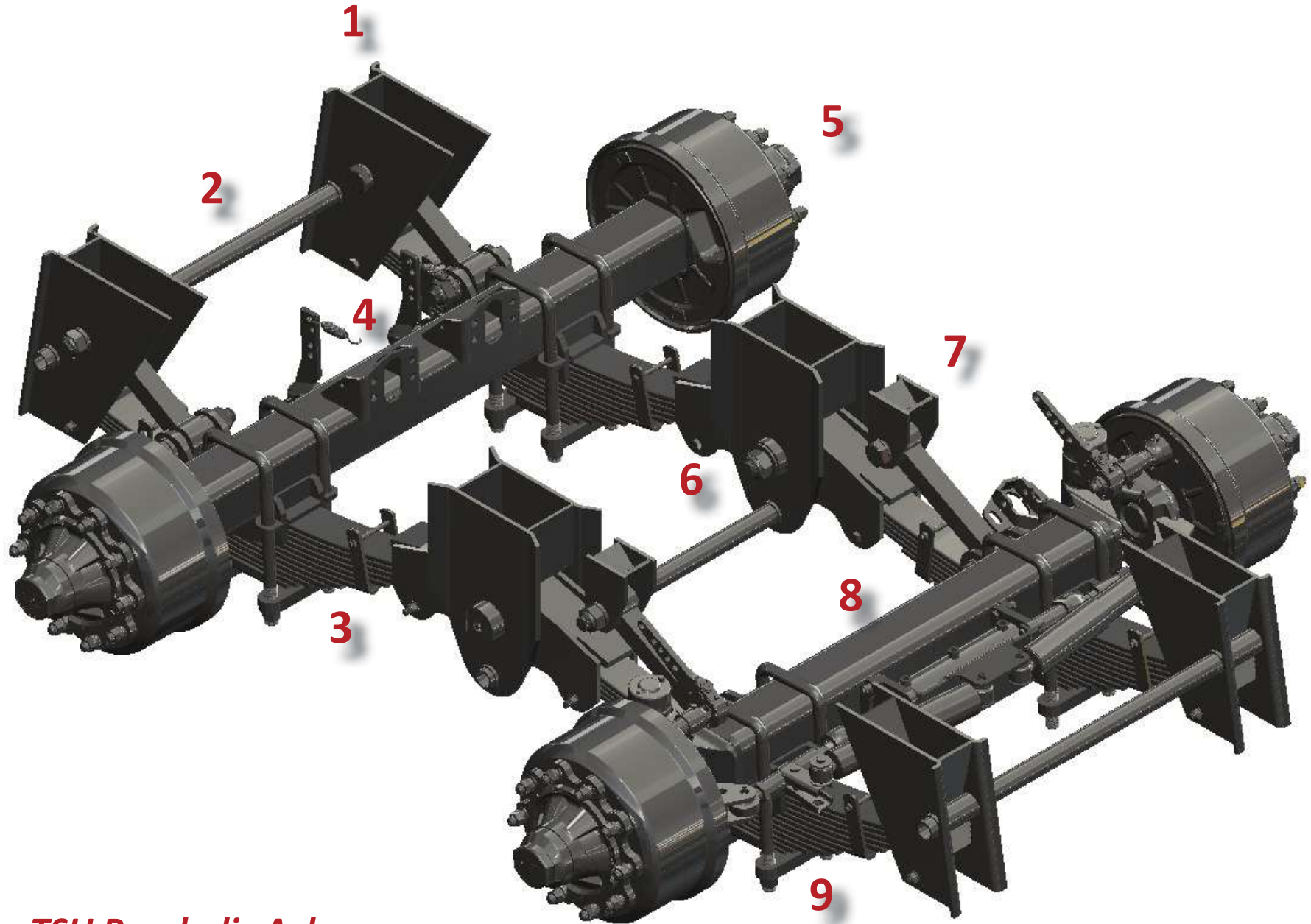

HiSpec TSU Parabolic Axle

Fully Loaded Running Gear

HiSpec TSU Axle

The TSU mechanical suspension is a heavy duty suspension ideally suited for slurry tankers that work in rough terrain and travel on roads at high speed. The TSU is under-slung to reduce the centre of gravity and increase stability. The heavy duty fabricated steel construction ensures a uniform, robust and high quality finish, while the torque arm design offers support and alignment suitable for high speed applications. Torque arms are fitted with high density poly bushes and assembled using large M36 bolts suitable for high loading. The torque arms are positioned above the spring for maximum ground clearance, whilst the centre hanger is assembled using heavy duty 70mm diameter pin and poly bushings.

1. The HiSpec TSU parabolic axle is welded to the tanker chassis via a carrier plate spanning from the front to rear hangers. These plates allow the axle to be welded to the chassis over its full length. This connection allows the stress and strains from the axle to pass along the length of the chassis as opposed to a conventional 'bogies' system where the stress and strains are passed through a small centre pivot.
2. Tie bars are fitted on the hangers to provide lateral support during turning. As the tandem axle is turning a huge lateral force is placed through the hangers and these tie bars provide stability and strength.
3. A 15mm x 100mm x 12 multi-leaf spring provides outstanding load capacity. The multi-leaf is under-slung to reduce tanker height.
4. 150 x 150 square axle beams provide large carrying capacity. The beam is placed above the springs for a reduced centre of gravity and improved stability.
5. A 10 stud commercial axle and hub provides large 420 x 180 hydraulic brakes as standard.
6. The centre hanger is fitted with heavy duty 70mm diameter pin and poly bushings. The centre hangers house the axle equaliser which controls manoeuvrability over uneven terrain.
7. Torque arms are fitted with high density poly bushes and assembled using large M36 bolts suitable for high loading. The torque arms are positioned above the spring for maximum ground clearance.
8. The TSU is fitted with passive rear steering as standard. The steering ram is hydraulically unlocked to allow the rear wheels to follow. The ram is hydraulically locked via tractor spool to reverse.
9. Prefabricated saddle and clamp plates are fitted above and below the springs. These plates are braced against the sides of the springs for additional strength and to relieve pressure from the U-bolts.





HiSpec TD-S

The HiSpec TD-S barrel is fully welded in 6mm British steel. The barrel is overlapped along the base and collared at the ends to ensure a robust cylinder. Rolled channel irons are fitted internally to act as a ribcage for the barrel. Reinforced baffles are placed at staggered intervals to eliminate surges during transport.

The barrel is placed on a full length chassis which is unique to HiSpec. The chassis is folded into troughs to support the barrel along its full length.

The chassis supports the barrel along key locations. Firstly, on both sides of the barrel overlap in the centre and secondly, along the outsides to transfer the weight safely the axle. The chassis accommodates additional reinforcement to facilitate low emission applicators on the rear.

The chassis acts as a solid foundation to support the barrel. The axle is married up to the underside of the chassis and placed towards the rear to aid balance and ensure adequate weight is transferred towards the tractor.

TS-R





Lower and narrower than before.

TS-R Tandem Semi - Recessed

TS-R is a upgraded version of the TD-S. Due to a specially lowered chassis and semi-recessed barrel we are able to manufacture TS-R lower and narrower than ever before.

The TS-R is built on a narrower parabolic axle than the TD-S. This reduced width immediately allows us to save over 150mm overall compared to a TD-S. The TS-R is fitted standard on 710/50 R26.5 tyres and the reduced width makes the TS-R ideal behind the tractor.

The lower chassis reduces the height by 200mm compared to a TD-S. This reduced height allows the TS-R to seat neatly behind the tractor and reduces the risk from overhanging obstacles.

The reduced height pushes the centre of gravity lower for further comfort and improved stability, reducing risk of overturning.

TS-R





So much more in a smaller frame

The TS-R gives much more in a smaller frame. The narrower overall width and reduced height allows the TS-R to travel easier over land. The large footprint tyres spread the weight, and the rear steering as standard allows the TS-R to follow effortlessly.

Internal baffles and supports are provided for strength. The full length chassis has additional bracing during manufacturing to cover any additional strain from an applicator.

The TS-R is a premium upgrade from the TD-S and ensures the operator has improved control, stability and comfort all within a smaller frame.

TS-R





TD-R //

Premium Performance

TD-R Tandem Axle - Recessed

TD-R tankers are recessed tandem tankers designed for high-end users. Features include a sprung drawbar, 11000 litre Jurop pump and recessed 750/60 R30.5 Alliance tyres. A high-speed axle complete with rear steering ensures that TD-R can travel anywhere, and get there fast. Capacities range from 3000 to 4000 gallons and this ensures TD-R tankers float across fields and from one job to the next.

A TD-R is particularly suited to contractors who want to overcome all obstacles. TD-R have wheels recessed into the tanker to keep the width of the tanker as narrow as possible; whilst also providing maximum ground coverage. The tyres feature a high-load index meaning they carry greater weight at faster speed and travel easily over land.









Chassis

TD-R tankers are fully supported by a unique folded chassis. The chassis is folded twice to support the barrel along four key-lines for its entire length. This ensures that the weight of the tanker is distributed evenly to the axle. The chassis is also fitted with internal reinforcement to cope with any additional stresses placed upon these high performance tankers. For improved comfort, reinforced baffles are fitted internally at staggered heights to prevent surging.

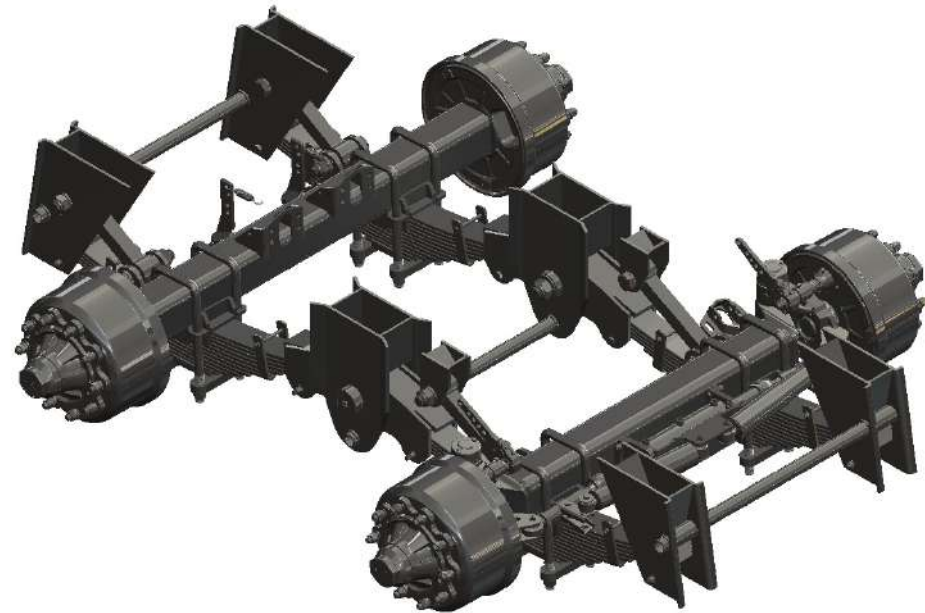

Parabolic Sprung Axle

TD-R are fitted on a parabolic high-speed tandem axle complete with rear steering. The parabolic axle is welded along the entire underside of the chassis for maximum strength. The axle is particularly suited to intensive road use as stresses and strains are transmitted along a greater distance than a conventional 'bogie' pivot. The suspension is under-slung to reduce the centre of gravity and increase stability. Axle spacings are positioned at 1,820mm to accommodate the large 30.5 wheels. 420x180 hydraulic brakes are provided with air over hydraulic an optional extra to further improve braking efficiency.





Built for Performance

TD-R are designed to work and built for performance. TD-R provides exceptional control on roads and in fields. TD-R are fitted on Alliance 750/60 R30.5 for unrivalled premium performance. High-speed load indexes and excellent flotation properties cater for the demands on these tyres.

These large 30.5 tyres improve comfort and travel, have a lower rolling resistance and ensure that your TD-R floats effortlessly behind your tractor.



ALLIANCE 885

Road 50% Field 50%

Sizes Available

30.5

750/60 R30.5 Alliance 885

Load Index

181 D



ALLIANCE 882

Road 75% Field 25%

Sizes Available

30.5

750/60 R30.5 Alliance 882

Load Index

181 D





CASE IH

HY-PEC

4000 TD-9

CASE IH

270





Self-steer Axle

TD-R is fitted with self-steering for excellent manoeuvrability. The steering is set to 'open' and 'locked' via hydraulic spool. Self-steering allows the rear axle to steer independently enabling it to follow the direction of the tractor.

The steering allows for 12 degrees of oscillation in both directions to ensure that TD-R follow effortlessly. The steering should be set to 'locked' to reverse and for all roadwork.

TD-R axles are also fitted with dampeners on the rear axle to reduce strain. This allows the axle to withstand forces that are exerted when turning sharply.



TRI-S



Three times the load

TRI-S means huge capacity spread over three axles. HiSpec offer TRI-S ranging from 4000 to 5000 gallons. Sitting on 560/60 R22.5, TRI-S are non-recessed triple axle tankers designed for maximum carrying capacity.

TRI-S use three high-speed commercial axles with the rear steering for manoeuvrability. TRI-S are ideal for use as ferry tankers, or field spreading when conditions allow. TRI-S move larger volumes of slurry than previously imagined and allow the operator to seriously increase output.





5000 TRI-3





Travel lightly, keep a large footprint

TRI-S are fitted on 560/60 R22.5 Alliance, and these allow for considerable carrying capacities on the road. These tyres have excellent self-cleaning properties and maintain a large footprint on the road for maximum control.

Thread patterns available include Alliance 885 and 882.

Alliance 885 combines the best properties of flotation and road ability to perform well on roads and fields. Alliance 882 possess a denser pattern to allow this tyre to maintain optimum grip on the road, but slightly less traction in the field.



ALLIANCE 885

Road 50% Field 50%



ALLIANCE 882

Road 75% Field 25%

Sizes Available

Load Index

22.5
560/60 R22.5 Alliance 885

159 D

26.5
650/55 R26.5 Alliance 885
710/50 R26.5 Alliance 885

170 D
170 D

Sizes Available

Load Index

22.5
560/60 R22.5 Alliance 882

159 D

26.5
650/55 R26.5 Alliance 882
710/50 R26.5 Alliance 882

170 D
172 D





Size matters, go bigger

TRI-S Tridem Axle - Standard

TRI-S are particularly suited to the transportation and spreading of larger volumes of slurry. TRI-S have been designed with a large diameter barrel in order to keep the overall length of the tanker as short as possible. The tridem parabolic axle fitted with 420x180 hydraulic brakes allows for maximum comfort on roads or fields. A full-length chassis allows the laden weight of the tanker to be distributed evenly over the running gear.

TRI-S tankers incorporate a durable painted finish and can be packed full of features as needed. Where tractor power is available, then TRI-S can make a positive solution to spreading of larger volumes over a shorter period of time.

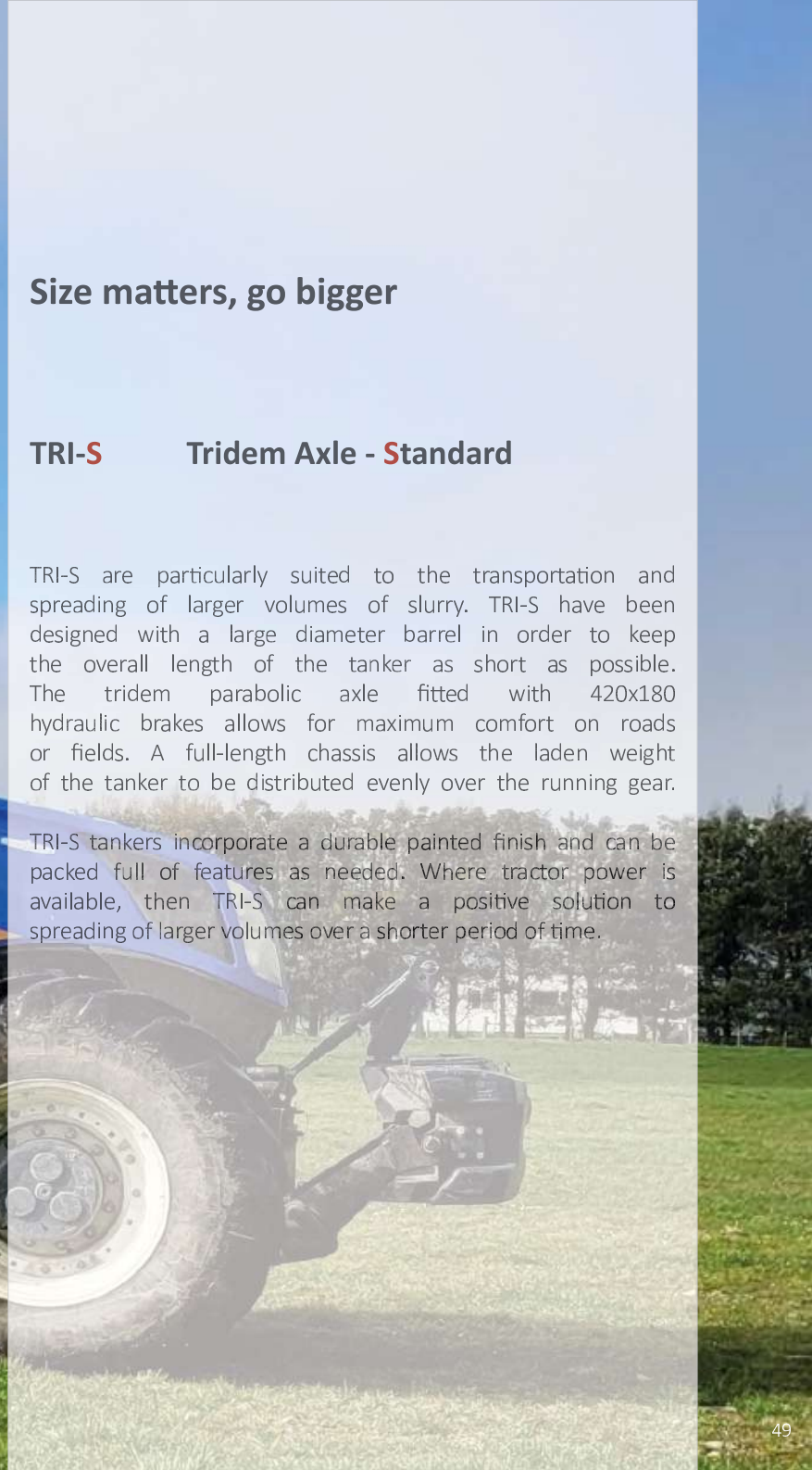



TRI-SR





Bigger Tyres but Smaller Size

TRI-SR Tridem - Semi Recessed

TRI-SR are upgraded by providing a semi-recess tanker on 710/50 R26.5 tyres. By recessing the tyres we are able to reduce the overall width of the tanker compared to a TRI-S. This recess also lowers the overall height too.

TRI-SR are manufactured from 4500 to 5000 gallons on a large dished to keep the overall length short. TRI-SR feature six large 710/50 R26.5 tyres as standard for excellent weight distribution and huge carrying capacity.

Maximum moving with the TRI-SR

The TRI-SR is the largest tanker in the HiSpec range to provide maximum movement of slurry. It features a large capacity barrel on a semi-recessed chassis. The TRI-SR is fitted standard on 710/50 R26.5 tyres to allow maximum flotation. Providing a semi-recessed chassis allows us to lower the overall height.

Featuring rear steering as standard the TRI-SR follows the tractor well. The large diameter barrel keeps the overall length as short as possible for entering and exiting yards.

The TRI-SR is sitting on a large commercial multi-leaf suspension which copes well with the huge weight demands placed. The multi-leaf axle is underslung to reduce height and features additional bracing which transfers strain evenly across the axle.





5000 TRI-SR

HI SPEC



Pumping Power

HiSpec use top quality Jurop pumps across our range of vacuum tanks. Designed and manufactured in a state-of-the-art factory in Italy, Jurop pumps are the fastest and most powerful available today. Each pump is assembled according to Jurop's methodical standards and is carefully tested and checked prior to despatch.

PTO driven as standard, the PN Series provide the most efficient method of filling or emptying your tank. Jurop pumps have a worldwide reputation for quality and minimal maintenance. Parts and service are available locally, and the premium build of Jurop ensures an extremely long life.

9000 litre Jurop PN84
11000 litre Jurop PN106
14000 litre Jurop PN140

up to 2000 gallon
2300 gallon upwards
optional

Upgrade your Jurop for maximum performance



Go safer

Hydraulically-driven pumps offer greater safety to the operator by eliminating the PTO. Increase efficiency with constant spreading through corners and filling through any angle without damage to the pump.



Go faster

Switch between vacuum and spreading at convenience and speed. Have your tank primed before you even reach the pit with a hydraulic changeover. The changeover keeps the operator away from the PTO to avoid unnecessary risks.



Go quieter

Reduce noise levels during operation and provide a cleaner environment around your tank. Exhaust air is directed through a purpose built silencer within the drawbar. Excess oil is collected within the drawbar to keep your pump and yard clean.





SPREAD ANYWHERE, ANYTIME

It's raining down

HiSpec use Jurop Julia centrifugal pumps for rain-gun spreading. Centrifugal systems are ideal for spreading in wet weather or over unfavourable ground. Centrifugal pumps rely on rotational force from a propellor to expel liquid under greater pressure and speed.

A hydraulically operated rain-gun can jet liquid through 360 degrees up to 50 metres. A stonetrapp complete with internal guard and wide angle PTO are provided as standard for pump protection.

As an optional extra, the rain-gun can pivot up and down for hard to reach places.



Jurop Julia 84
Jurop Julia 106
Jurop Julia 140

up to 2000 gallon
2300 gallon upwards
optional

Juop



Optional up / down rain-gun

UMBILICAL SPREADING

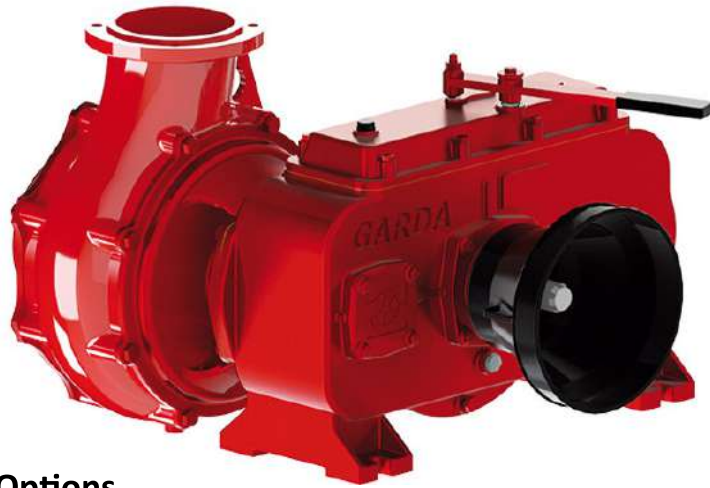

Umbilical Pump Options

HiSpec tankers can be used in conjunction with centrifugal pumps to accelerate umbilical spreading.

Depending on the pumping distance required, HiSpec have a pump that suits.

- 1. Battioni GARDA** **700 metres**
A proven pump for splashplate spreading and umbilical work up to 700 metres. PTO driven as standard, choose between the Battioni vacuum for filling and splashplating or the GARDA centrifugal for umbilical or rain-gun spreading.
- 2. Battioni EVO c/w DODA L35** **1,500 metres**
Comprises an 11000 litre Battioni for filling and splashplate spreading and a DODA L35 centrifugal for heavy umbilical work. Doda L35 is capable of umbilical pumping up to 1,500 metres. Both pumps operated via PTO.
- 3. Jurop Hydraulic c/w DODA L35** **1,500 metres**
A high-powered pto driven DODA L35 on the drawbar for umbilical work complete with a side-mounted Jurop hydraulic pump for filling and splashplate spreading.





UMBILICAL CONNECTIONS

SAFALLA

A SAFALLA is the most secure connection to your umbilical piping. SAFALLA (*Self Aligning Fully Automatic Latching & Locking Arm*) comprises of an automatic connection between your tanker and umbilical system. The SAFALLA is hydraulically lowered to a non-return pod and eliminates handling dirty pipes and adjusting hand-operated valves.

The SAFALLA is aligned up to the pod and hydraulically lowered to connect. The 4" hydraulic gate valve is then opened and pumping can commence. All of this is completed quickly and efficiently from the cab.

4" BALL VALVE

4" ball valves can be fitted to either side of the centrifugal pump to supply either direction. It is necessary to manually clamp your umbilical pipe to the ball valve each time unless the centrifugal pump is being used as a stationary tanker.

The 4" ball valve offers a more economical option over the SAFALLA.



LEVEL INDICATORS



3" Bubbles

100mm Sight Tube

Portholes (x3)

Know when you're full

3" Bubbles

3" sight bubbles are standard to inspect slurry level. Additional bubbles can be fitted to any position on the front or rear dish as required.

100mm Sight Tube

A 100mm diameter sight tube can be fitted to give a more accurate indicator of slurry level. The sight tube is manufactured from industrial perspex. It is an excellent indicator of slurry level for both filling and emptying.

Portholes

A set (3) of portholes can be fitted to either dished end. These allow a window into the barrel at the top, middle and bottom to monitor liquid level.

FILLING UP

Hoses and fill points

All tankers come standard with:

6" galvanised quick attach (PERROT)	x 1
6" blank fill point	x 3
6" x 15' reinforced suction hose	x 1
6" hose carriers	x 1 side



Additional quick attaches and hoses may be added as optional extras.

HiSpec uses perrot couplings and a sliding quick attach to clamp the suction hose to the tanker. The perrot fitting is seen as the strongest connection available, however the suction hose needs to be aligned straighter to secure.

A 6" x 15' reinforced suction hose is supplied as standard. Hoses can also be supplied in 20' length and with the addition of double-end fittings for longer lengths. 6" pipework is the most common size due to its ease of use and relative low weight.

Pipework is also available in 8" diameter to increase flow rate and provide improved suction with thicker slurry. 8" will fill the tanker faster than the 6", however the additional weight and handling of the 8" will need to be considered.

STORAGE AND CONVENIENCE



5 litre oil holder

Water and soap dispenser

Soap and Water Keep clean as you go



A 20 litre water tank with soap dispenser allows you to keep your hands clean before getting back into the cab. Top up with fresh water as required.

A 5 litre oil drum holder can also be fitted for maintaining pump levels.

Tool Box

Carry your tools with you

Carry the tools you need to suit individual jobs. Toolbox is galvanised and lockable.



Stonetrap

Keep stones collected

A stonetrap is used for the collection of stones. Stones must pass over the trap where they are then collected. The trap can be opened manually to release build-up.



Internal Agitator

Keep it from settling

A hydraulically operated internal agitator prevents sand or sediment resting on the floor. The agitator keeps the slurry in motion and runs for the entire length of the barrel.



600mm Side Door

Keep it clean

A 600mm side access manhole can be fitted to allow for easy cleaning; particularly when a low emission spreader is fitted.



4 Point Linkage

Carry any implement

Fitting a four point linkage to your tanker allows you to carry larger applicators. The linkage is hydraulically raised or lower as needed.

The four point linkage is mounted on the rear with additional bracing and reinforcement along the chassis to counteract any additional stresses.

The four point linkage is versatile and can carry any applicator. It is also easy to remove the applicator and revert to a conventional tanker.

Brackets only can be factory fitted at manufacturing which allows the bolting on of the linkage at a later date.





BE SAFE, BE SEEN

Lighting and Visibility

Be safe, be seen, light up

HiSpec tankers are fitted with one set of LED road-lights. Additional road-lights and beacons can be added to increase visibility and provide warning to other road users.

LED Road-lights

Add a second set of road-lights up high to increase visibility to other road users.



LED Flashing Beacon

A flashing amber LED beacon alerts approaching traffic.



LED Strobes

Amber pulsing strobes give advanced warning to traffic approaching from the rear.



LED Worklight

Add one or multiple LED worklights to keep the work going late into the evening or night.



Rear Camera

A rear camera can be fitted for manoeuvring into difficult places and to monitor spreading.



AUTO-FILL AND TURBO-FILL

Auto-Fill

No waiting around

Available in either 6" or 8", our Auto-fill maximises productivity and comfort while simultaneously reducing work load.

The Auto-fill requires only a double acting spool for use. Firstly, the pump is hydraulically set to fill and this action pinches an air line at the same time.

In sequence, the autofill arm descends into the galvanised tripod to form an air-tight seal. The hydraulic gate valve opens and filling can commence.



Turbo-fill

Put your pump into turbo

Experience the ultimate in filling speed with an 8" Turbo-fill. The Turbo-fill is supplied in addition to the 8" Auto-fill. A hydraulically driven Turbo-fill enables higher capacities without overloading the pump. Filling time is reduced as the slurry is forced into the tank. It also helps to reduce froth levels.

The Turbo-fill is particularly suited to large capacity tankers where the full benefit of filling will be seen.

It is useful where the level of slurry has dropped in the pit and the pump is struggling to fill from greater depths.



LOADING AND UNLOADING

Top Filling

Sliding Top-fill

The sliding top-fill hatch opens horizontally to reduce the risk of contact. A hydraulic ram slides the hatch shut against steel rollers and a rubber seal to close. Galvanised finish as standard.



Unloading Boom

The unloading boom is designed to feed an additional working tanker or nursery. The boom is ideal where time savings are required.

The boom can be rotated through 270 degrees making it possible to unload on both sides of the tanker. The boom length means that hedges can be easily bridged.

The boom is galvanised and features a drip tray to pass excess slurry neatly to the ground.





SAFETY, COMFORT & CONTROL



Spoon Hitch

Smoother travel

A spoon hitch offers 90% less wear and damage than traditional ring hitches. The ball and spoon coupling ensures a perfect fit between tanker and tractor, which facilitates greater comfort, safety and control.

A HiSpec tanker comes with a 50mm ring hitch which can be upgraded to a ball and spoon coupling. The ball and spoon coupling eliminates shunting associated with traditional ring hitches.

A bolt-on ring hitch (*below*) can be fitted to the drawbar to future proof the fitting of a spoon.



Air Brakes

Improved stopping power

Increased road work and higher tractor speeds means braking must be a top priority. HiSpec tankers SA-R and above are fitted with a commercial axle with large 420x180 hydraulic brakes.

For additional safety and improved braking, air over hydraulic brakes can be fitted. A large air reservoir and load sensing relay gives a crisper braking than hydraulic brakes.



Forced Steering

Follow the tractor

Fitted with the spoon hitch, the option of forced steering maximises control. The operator does not worry about locking or unlocking the steering. The extension and retraction of the steering ram on the drawbar controls the direction of the wheels.

Overall tyre wear is reduced as dragging is reduced. It is also easier to reverse the tanker as the rear wheels do not need to be hydraulically 'locked' out.



Central Grease Bank

Maintenance made easy

Suitable for tandem and triple axle tankers, all axle grease points are routed to an easily accessible bank. The operator can easily apply grease to extend life and reduce maintenance.



Digidevice Touch Controller

Touch of a button

The Digidevice ICON-D controller provides touch button controls with an advanced setup. Used via load-sensing hydraulics a small handheld unit with customisable display highlights individual functions to the operator.

A large multitude of functions are possible with the ICON-D able to display numerous screens.



Vogelsang Rotacut

Macerate as you fill

The Vogelsang Rotacut is fitted to a standard 6" quick attach. The Rotacut is hydraulically driven via tractor spool. As the tanker is filling, the Rotacut macerates fibres against a mesh screen. The mesh screen prevents the passage of stones or lumps into the tanker.

The Rotacut can be driven in both directions to ensure even wear. As a result, the blades and screen are always in contact and you benefit from optimal cutting performance.

The front of the Rotacut features a 2" perspex sight bubble to monitor filling. The front compartment acts as a sump for stones, which can be easily removed, when the Rotacut is switched off.



The Alliance Line Up



The tyres on your tanker are the only part in contact with the ground so HiSpec has teamed up with Alliance to offer premium solutions for increased carrying capacity and reduced ground compaction.

All tyres are manufactured to the highest standard and feature high load index for extended life. A variety of patterns are available, from the tractor grip for increased grip and low overall rolling resistance. The 882 pattern is available for mixed use on both roads and field, while the 885 pattern has additional grip and is suited to intensive road work.



Model	Tyre	Optional
800 SA-S	1	2, 3
1150 SA-S	1	2, 3
1350 SA-S	2	3
1600 SA-S	2	3
2000 SA-S	4	N/A



1

15 x 22.5

385 (15") 1080 (42")

15 x 22.5 tyres are particularly suitable for smaller machines. Their width 385mm is ideal around small farm yards or hard surfaces.

15x22.5 offers long wear resistance but limited flotation.



2

550/60 - 22.5

550 (22") 1234 (49")

Load Index 154 A8

550/60 - 22.5 are designed for carrying high loads at low pressure, reducing soil compaction and preventing damage.

The most common choice of tyre for SA-S as the large overall width helps spread the load over a greater area.



3

540/70 R24

540 (21") 1400 (55")

Load Index 155 A8

Non-recessed 540/70 R24 can be fitted to provide improved grip on sloped ground.

The tractor grip helps to prevent the tanker from sliding on inclines. These tyres are larger in diameter and provide lower rolling resistance.



4

560/60 R22.5

543 (21") 1244 (49")

Load Index 161 D

560/60 R22.5 is the ideal multi-purpose tyre for use on roads or fields. The higher carrying capacity means this tyre is fitted standard on the 2000 SA-S.

The high-load index ensures this tyre is suitable for intense road use.



5

750/70 R26 Alliance (28.1)

750 (29") 1780 (70")

Load Index 158 A8

Alliance 750/70 R26 is a wide base radial tyre developed for field and hauling applications. The large footprint area reduces average ground pressure, minimises soil compaction and increases flotation abilities.

Ideal for farmers completing their own work or for tractor speeds under 40 km/h.



6

800/65 R32 Alliance (30.5)

800 (31") 1850 (73")

Load Index 181 A8

Alliance 800/65 R32 is an extra wide base radial tyre for higher capacities. Low angled lugs at the shoulders improve traction, while higher centres improve ride comfort. Load index of 181 A8 translates to 8,250kgs per tyre at 40km/h.

Recommended for contractors and tractors capable of 50 km/h.



Model	Tyre	Optional
1350 SA-R	5	6
1600 SA-R	5	6
2000 SA-R	5	6
2300 SA-R	5	6
2600 SA-R	6	N/A
3000 SA-R	7	N/A

Model	Tyre	Optional
3000 TD-S	9	10, 11
3500 TD-S	9	10, 11
4000 TD-S	9	10, 11

Model	Tyre	Optional
3000 TS-R	10	11
3500 TS-R	10	11
4000 TS-R	10	11

Model	Tyre	Optional
3000 TD-R	7	8
3500 TD-R	7	8
4000 TD-R	7	8

Model	Tyre	Optional
4000 TRI-S	9	10, 11
4500 TRI-S	9	10, 11
5000 TRI-S	9	10, 11

Model	Tyre	Optional
5000 TRI-SR	10	11
5500 TRI-SR	10	11
6000 TRI-SR	10	11



7



8



9



10



11

750/60 R30.5 Alliance (885)

767 (30") 1680 (66")

Load Index 181 D

750/60 R30.5 Alliance 885 is a new generation tyre with a high load carrying capacity, working speed and superior distribution of pressure. Lower rolling resistance enhances fuel efficiency.

Load index of 181 D ensures each tyre is capable of carrying 8,250 kgs at 65 km/h.

750/60 R30.5 Alliance (882)

754 (30") 1675 (66")

Load Index 181 D

Alliance 882 implement tyres combines the best characteristics of flotation tyres and radial construction to provide superior performance on road and in field applications.

One of its best features is a strong fabric carcass reinforced by rigid steel belts. Its directional block configuration ensures the best possible self-cleaning ability.

Due to its internal volume, the tyre is characterised by low inflation pressure that promises low soil compaction for very high load capacity.

560/60 R22.5 Alliance (885)

555 (22") 1230 (48")

Load Index 164 D

Alliance 885 is a new generation tyre with a high load carrying capacity, working speed and superior distribution of pressure. Lower rolling resistance enhances fuel efficiency.

It is a steel belted construction that ensures lower downtime leading to lower maintenance costs and strong casing that provides higher wear resistance.

Load index of 164 D equates to 5,000 kgs per tyre at 65 km/h.

710/50 R26.5 Alliance (885)

732 (29") 1400 (55")

Load Index 170 D

Alliance 885 is a new generation tyre with a high load carrying capacity, working speed and superior distribution of pressure. Lower rolling resistance enhances efficiency.

Top performance tyre suitable for 6,000 kgs per tyre at speeds up to 65 km/h.

710/50 R26.5 Alliance (882)

727 (29") 1383 (55")

Load Index 172 D

Alliance 882 combines the best characteristics of flotation and radial construction to provide a superior performance on road applications.

Ideal for high-performance on the road. These tyres are non-recessed but provide low rolling resistance and low wear. 710/50 R26.5 are seen as the top choice for their higher index and greater footprint.





HiSpec Dribble-**Bars**



7.5m Chassis Dribble Bar

HiSpec manufacture their own dribble bars to provide a factory fit solution for low emission spreading.

Chassis Mounted

Weighing in at just 500kgs, our 7.5m dribble bar is supported on the tank chassis. Additional reinforcement is placed along the chassis to support the dribble bar. There is no weight carried on the rear manhole. The dribble bar is also easy removable. By removing the stabilier pin, the dribble bar can be lifted away allowing the tanker to revert to a conventional setup. All hydraulics connections are quick release.

Galvanised

The dribble bar is lightweight yet fully galvanised. The distributor and arms are carried on the fixed mast and both arms are spring loaded for protection.

Slurry Outlet

The slurry outlet is fitted on the side of the manhole. This position means no internal pipework that could cause blockages, and allows us to feed the dribble bar externally at an ideal height. A junction box is attached for rear filling, stone collection and splashplating. The junction box has an outlet underneath for the removal of stones.

Lay Flat Hoses

Large diameter 40mm outlet pipes allow a precise flow of slurry to the lay-flat hosing. The lay flat hosing boasts high ground clearance which is a benefit over uneven ground.

Spring Loaded Arms

Spring loaded arms protect the dribble bar from collision. The spring allows the arm to break back through 90 degrees for safety.





HiSPEC
UNIVERSITY-CLASS PESTICIDE CONTROL

Tom Shaw
SALES MANAGER LTD
www.tomshaw.co.uk

2600 SA-1

HiSPEC

Orange light

DANGER
Pesticide
Get full info on label



HiSpec Trail-S





HISPEC TRAIL-S

HiSpec is now offering an in-house trailing shoe to complement our tanker range.

Available in three working widths, the Trail-S range from:

Trail-S 7.5	7.5 metres	30 outlets
Trail-S 9.0	9.0 metres	36 outlets
Trail-S 10.5	10.5 metres	42 outlets

A trailing shoe will deliver one of the most efficient uses of slurry. A hardened steel "shoe" parts the grass and creates a channel on the ground. A "trailing" rubber boot then deposits the slurry directly into this channel underneath the grass. The steel shoe and rubber boot are fitted to a high tensile spring leg. This spring leg provides "constant pressure" on the ground to create the slurry channel. The creation of this channel allows the slurry to be absorbed faster and avoids grass contamination. Once spreading is complete, the parted grass covers the slurry, minimising evaporation.

The HiSpec Trail-S is chassis mounted to support the additional loading and operation of the shoe. The axle is positioned further towards the rear to aid balance. The Trail-S features a fully galvanised frame and unique pivot action. Our pivoting action eliminates the need for a separate mast and helps to reduce the overall height. The entire Trail-S is also easily removed if required.

Another unique feature of the Trail-S lies in its simple folding. Two offset arms fold at the top to reduce overall height. The wider Trail-S are fitted with sequenced valves to ensure timed operation. This unique folding allows the Trail-S to fit neatly behind the tanker.

The Trail-S is fitted with efficient traits to ensure easy operation. A splashplate is supplied on the rear and switching between shoe and splashplate is simple via changing spools at the tractor. The splashplate is fed directly from the rear manhole and there are no dirty hoses to switch from shoe to splashplate. The operator has independent control over the height that they wish to spread, and the shoe can also be operated as a dribble bar if required.

The Trail-S is fitted with two independent stonetraps, and another is possible on the tanker itself. Slurry enters the Trail-S from the side of the manhole and stones are forced out the man-hole to the galvanised stone box for easy removal. Smaller stones that remain in the slurry will pass through the macerator where they will drop into the collection sock.



Individually sprung legs with hardened steel coulters

TRAIL-S

The Trail-S features individually sprung tensile legs with hardened steel coulters to part the grass and open the soil. The downward pressure applied through the tensile leg ensures that the shoe is in constant contact with the ground.

This constant pressure of approximately 8kg per leg is vital to create the optimum channel for slurry uptake. The trailing rubber boot then deposits the slurry directly into this open channel.

Once spreading is complete, the parted grass comes together again, minimising evaporation and saving on fertiliser.





1. Folding Ends

The Trail-S fold away nicely. All Trail-S feature folding ends to reduce overall height. Keeping the overall height reduced allows HiSpec to provide a unique solution that looks impressive on the rear of the tank.

2. Stone Box and Fill Points

The Trail-S is fitted with an external stone box. The stone box helps to collect stones that are pushed through the rear manhole. The stone box also acts as a rear fill point to allow filling from behind.

3. Stone Sock

Slurry is passed directly into the macerator from the side of the manhole. Any small stones or grit that are present in the slurry will enter the macerator and fall into the stone sock. The sock can be squeezed to test for stones and emptied as required.

4. Splashplate

A splashplate is fitted at the rear of the Trail-S. The splashplate is fitted at normal operating height and fed directly from the tanker. There is no handling dirty pipes to switch between shoe and splashplate. The splashplate and stone box are removable to reduce weight if not required.

5. Slurry Outlet

HiSpec position the slurry outlet on the side of the manhole for a number of reasons. Firstly, it allows the tanker to empty completely. Secondly, there are no internal pipes to cause blockages. Additionally, the outlet is located externally at ideal level for maintenance or inspection.



HiSpec Trail-S

Fold it away

Much of the success of the HiSpec Trail-S lies with its unique folding. HiSpec has taken the folding of the Trail-S to a new dimension with our parallel arms. Our unique parallel folding of the outer arms allows us to dramatically reduce overall height. The Trail-S features the lowest transport height of a shoe on the market.

During transport the Trail-S has high ground clearance and folds neatly behind the tanker. The shoe can be manually locked in position when not in use. The Trail-S features sequenced folding and unfolding for ease of use. The low overall weight is also perfectly balanced on the tanker as the axle is moved back to accommodate the shoe.

Serious shoe for serious output

The Trail-S comes standard with all the features required for serious output. The mast is chassis mounted to withstand stresses and strains. The arms feature a unique parallel folding to fit in nicely behind the tanker during transport. The trailing legs are made from high tensile steel to create constant downward pressure onto the ground.

Toughened 'V shaped' coulters part the grass and open the soil for increased slurry uptake and improved grass growth. The trailing rubber boot presents the slurry in a neat line directly into this channel.

The Trail-S features a fully galvanised robust frame for long life. The external stone box collects stones during operation and allows splashplating at convenience. The rear fill points allow the operator to fill from behind. The Trail-S features an LED road lighting kit to alert road users.

The working widths of the Trail-S covers all bases and has everything you need for more efficient slurry use and improved grass growth.





HISPEC MACERATOR



HiSpec Macerator

HiSpec manufacture their own macerator for use on all our applicators. By manufacturing our own macerator it allows us to be up to date with the market and provide complete control over production.

The macerator is circular in shape and features three double edged blades per side. Each blade is individually tensioned and self-sharpens against the cutting screen. The smaller surface area of the blade helps to prolong blade life as less force is required to tension the blade. The tensioning springs are housed so they are protected within the macerator. The macerator can run in either direction to wear blades evenly.

HiSpec use the same rotor and blades for their 7.5m and 9m units to aid production and provide continuity of parts.

The slurry inlet is fitted to the top of the macerator to allow all slurry to pass through the macerator. Stone and grit falls to rest in the collection sock below. The rotor is driven via hydraulic motor mounted on the left hand side. The right hand side provides access for blade replacement. An access hatch is provided on the back of the macerator for quick inspection.



Access Hatch

Access hatch at rear is easily opened for quick inspection.

Stone sock shown as blue lay-flat.

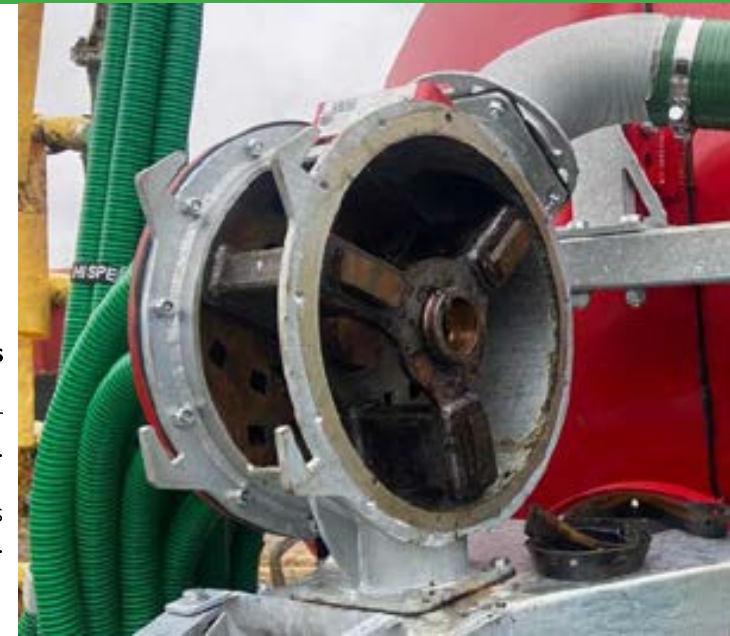

Three Double Sided Blades

Three spinning blades and a large rotor distribute the slurry evenly to the outlets.

The blades macerate the slurry as it comes against the outlet screen.



Self-Sharpening Blades

Self sharpening blades are tensioned against the cutting screens via internal springs and inserts.

Springs are protected within the rotor frame. Blades are self sharpening and can operate in either direction.



Blade Replacement

The blades can be easily removed and replaced. Inserts are visible that keep the blade tensioned.

TECHNICAL

SA-S Single Axle - Standard

Standard specification includes:

50mm ring hitch, parking brake, 9000 litre Jurop pump, PTO, manual pump changeover, protection shut off syphon, 6mm steel barrel, anti-implosion rings, 3" sight bubbles (x2), 6" galvanised quick attach (x1), 6" blanked fill point (x3), 6" hose carriers (1 side), 6" x 15' reinforced suction hose, hydraulic brakes, LED road-lights (x1), 600mm galvanised hinged rear door, splashplate, 2" wash-down adaptor, HiSpec red paint finish.

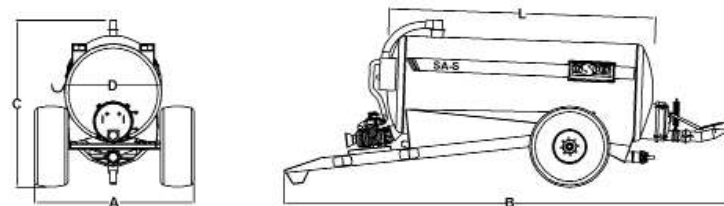

Model	Standard Tyre	Axle Size	Brake Size	Pump	Width A	Length B	Height C	Diameter D	Length L	Unladen kg	Litres
800 SA-S	15 x 22.5	80 x 80	300 x 90	9000	2260	5540	2360	1372 (54")	2500	1690	3660
1150 SA-S	15 x 22.5	80 x 80	300 x 90	9000	2260	6295	2450	1372 (54")	3050	1800	5228
1350 SA-S	550/60- 22.5	80 x 80	300 x 90	9000	2550	6425	2550	1524 (60")	3080	2000	6319
1600 SA-S	550/60- 22.5	80 x 80	300 x 90	9000	2550	7245	2650	1524 (60")	3660	2275	7501
2000 SA-S	560/60 R22.5	100 x 100	400 x 80	9000	2560	7305	2850	1740 (68")	3660	2500	9547

Mudguards standard from 1350 SA-S upwards

SA-R Single Axle - Recessed

Standard specification includes:

50mm swivel ring hitch, sprung drawbar, parking brake, Jurop pump, PTO, manual pump changeover, protection shut off syphon, 6mm steel barrel, anti-implosion rings, internal baffles, 3" sight bubbles (x2), 6" galvanised quick attach (x1), 6" blanked fill point (x3), 6" hose carriers (1 side), 6" x 15' reinforced suction hose, commercial axle, 420x180 hydraulic brakes, LED road-lights (x1), built-in round mudguards, 600mm galvanised hinged rear door, splashplate, 2" wash-down adaptor, HiSpec red paint finish.

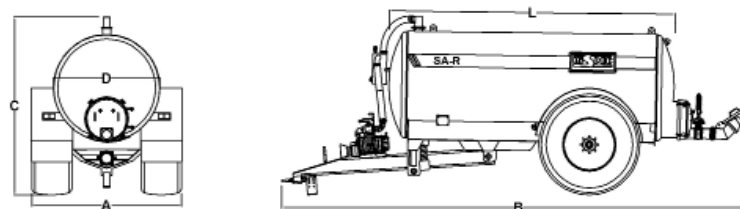

Model	Standard Tyre	Axle	Axle Size	Brake Size	Commercial	Pump	Width A	Length B	Height C	Diameter D	Length L	Unladen kg	Litres
1350 SA-R	750/70 R26 (28.1)	Stepped	150 x 150	420 x 180	Yes	9000	2580	6425	2820	1524 (60")	3670	3000	6137
1600 SA-R	750/70 R26 (28.1)	Stepped	150 x 150	420 x 180	Yes	9000	2580	7245	2820	1524 (60")	4250	3300	7273
2000 SA-R	750/70 R26 (28.1)	Stepped	150 x 150	420 x 180	Yes	9000	2580	7305	2950	1740 (68")	4250	3680	9183
2300 SA-R	750/70 R26 (28.1)	Stepped	150 x 150	420 x 180	Yes	11000	2580	7245	3050	1866 (73")	4300	3900	10547
2600 SA-R	800/65 R32 (30.5)	Straight	150 x 150	420 x 180	Yes	11000	2630	8145	3050	1866 (73")	4910	4800	11593
3000 SA-R	750/60 R30.5	Straight	150 x 150	420 x 200	Yes	11000	2600	8775	3100	1866 (73")	5540	5200	13784

Please note that brand of tyre supplied may vary according to availability at time of manufacture.

TECHNICAL

TD-S Tandem - Standard

Standard specification includes:

50mm swivel ring hitch, sprung drawbar, parking brake, 11000 litre Jurop pump, PTO, manual pump changeover, protection shut off syphon, 6mm steel barrel, anti-implosion rings, internal baffles, 3" sight bubbles (x2), 6" galvanised quick attach (x1), 6" blanked fill point (x3), 6" hose carriers (1 side), 6" x 15' suction hose, parabolic tandem commercial axle c/w rear steering, 420x180 hydraulic brakes, LED road-lights (x1), straight non-recessed mudguards, 600mm galvanised hinged rear door, splashplate, 2" wash-down adaptor, HiSpec red paint finish.

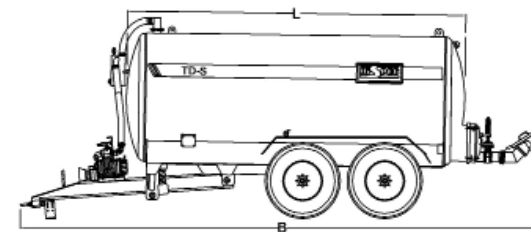
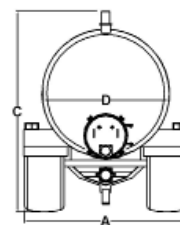

Model	Standard Tyre	Steering	Axle Size	Brake Size	Commercial	Pump	Width A	Length B	Height C	Diameter D	Length L	Unladen kg	Litres
3000 TD-S	560/60 R22.5	Rear	2 x 150	420 x 180	Yes	11000	2660	8775	3200	1866 (73")	5540	6050	14030
3500 TD-S	560/60 R22.5	Rear	2 x 150	420 x 180	Yes	11000	2660	8915	3200	1866 (73")	6060	6350	15911
4000 TD-S	580/65 R22.5	Rear	2 x 150	420 x 180	Yes	11000	2660	8915	3350	1993 (78")	6060	6700	18866

Please note that brand of tyre supplied may vary according to availability at time of manufacture.

TS-R Tandem Semi - Recessed

Standard specification includes:

50mm swivel ring hitch, sprung drawbar, parking brake, 11000 litre Jurop pump, PTO, manual pump changeover, protection shut off syphon, 6mm steel barrel, anti-implosion rings, internal baffles, 3" sight bubbles (x2), 6" galvanised quick attach (x1), 6" blanked fill point (x3), 6" hose carriers (1 side), 6" x 15' reinforced suction hose, parabolic tandem commercial axle c/w rear steering, 420x180 hydraulic brakes, 710/50 R26.5 tyres, semi-recessed built-in mudguards, LED road-lights (x1), 600mm galvanised hinged rear door, splashplate, 2" wash-down adaptor, HiSpec red paint finish.

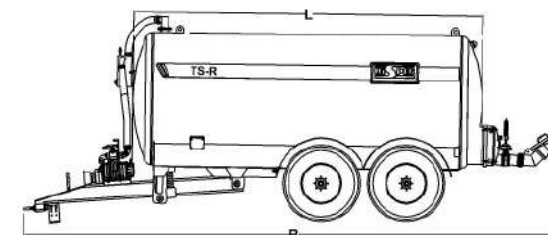
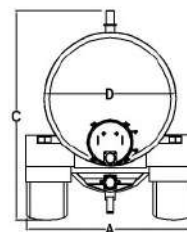

Model	Standard Tyre	Steering	Axle Size	Brake Size	Commercial	Pump	Width A	Length B	Height C	Diameter D	Length L	Unladen kg	Litres
3000 TS-R	710/50 R26.5	Rear	2 x 150	420 x 180	Yes	11000	2750	8500	3200	1886 (73")	5540	7050	14030
3500 TS-R	710/50 R26.5	Rear	2 x 150	420 x 180	Yes	11000	2750	9000	3200	1866 (73")	6060	7350	15911
4000 TS-R	710/50 R26.5	Rear	2 x 150	420 x 180	Yes	11000	2750	9000	3350	1993 (78")	6060	7700	18866

Please note that brand of tyre supplied may vary according to availability at time of manufacture.

TD-R Tandem - Recessed

Standard specification includes:

50mm swivel ring hitch, sprung drawbar, parking brake, 11000 litre Jurop pump, PTO, manual pump changeover, protection shut off syphon, 6mm steel barrel, anti-implosion rings, internal baffles, 3" sight bubbles (x2), 6" galvanised quick attach (x1), 6" blanked fill point (x3), 6" hose carriers (1 side), 6" x 15' reinforced suction hose, parabolic tandem commercial axle c/w rear steering, 420x180 hydraulic brakes, 750/60 R30.5 tyres, LED road-lights (x1), 600mm galvanised hinged rear door, splashplate, 2" wash-down adaptor, HiSpec red paint finish.

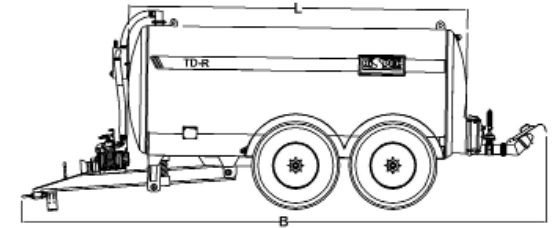
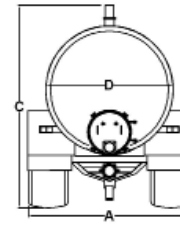

Model	Standard Tyre	Steering	Axle Size	Brake Size	Commercial	Pump	Width A	Length B	Height C	Diameter D	Length L	Unladen kg	Litres
3000 TD-R	750/60 R30.5	Rear	2 x 150	420 x 180	Yes	11000	2850	8775	3200	1886 (73")	5180	7700	14030
3500 TD-R	750/60 R30.5	Rear	2 x 150	420 x 180	Yes	11000	2850	9575	3200	1866 (73")	5600	8100	15911
4000 TD-R	750/60 R30.5	Rear	2 x 150	420 x 180	Yes	11000	2850	9575	3350	1993 (78")	5600	8500	18866

Please note that brand of tyre supplied may vary according to availability at time of manufacture.

TECHNICAL

TRI-S Tridem - Standard

Standard specification includes:

50mm swivel ring hitch, sprung drawbar, parking brake, 11000 litre Jurop pump, PTO, manual pump changeover, protection shut off syphon, 6mm steel barrel, anti-implosion rings, internal baffles, 3" sight bubbles (x2), 6" galvanised quick attach (x1), 6" blanked fill point (x3), 6" hose carriers (1 side), 6" x 15' reinforced suction hose, tridem commercial axle c/w rear steering, 420x180 hydraulic brakes, LED road-lights (x1), mudguards, 600mm galvanised hinged rear door, splashplate, 2" wash-down adaptor, HiSpec red paint finish.

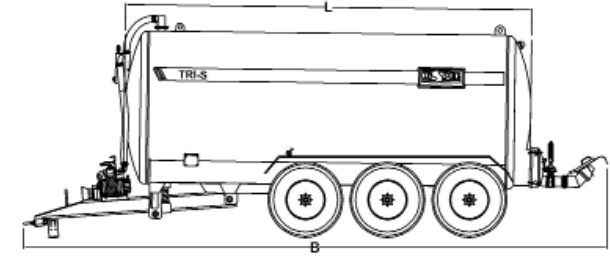

Model	Standard Tyre	Steering	Axle Size	Brake Size	Commercial	Pump	Width A	Length B	Height C	Diameter D	Length L	Unladen kg	Litres
4000 TRI-S	560/60 R22.5	Rear	3 x 150	420 x 180	Yes	11000	2710	8260	3400	2133 (84")	6160	7750	18866
4500 TRI-S	560/60 R22.5	Rear	3 x 150	420 x 180	Yes	11000	2710	8500	3400	2133 (84")	6410	7980	20457
5000 TRI-S	560/60 R22.5	Rear	3 x 150	420 x 180	Yes	11000	2710	8750	3400	2133 (84")	6660	8250	22730

Please note that brand of tyre supplied may vary according to availability at time of manufacture.

TRI-SR Tridem - Semi Recessed

Standard specification includes:

50mm swivel ring hitch, sprung drawbar, parking brake, 11000 litre Jurop pump, PTO, manual pump changeover, protection shut off syphon, 6mm steel barrel, anti-implosion rings, internal baffles, 3" sight bubbles (x2), 6" galvanised quick attach (x1), 6" blanked fill point (x3), 6" hose carriers (1 side), 6" x 15' reinforced suction hose, tridem commercial axle c/w rear steering, 710/50 R26.5 Alliance tyres, 420x180 hydraulic brakes, LED road-lights (x1), semi-recessed built-in round mudguards, 600mm galvanised hinged rear door, splashplate, 2" wash-down adaptor, HiSpec red paint finish.

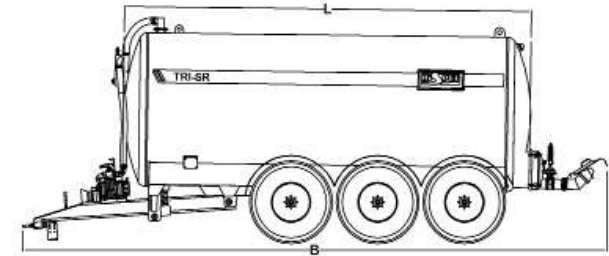

Model	Standard Tyre	Steering	Axle Size	Brake Size	Commercial	Pump	Width A	Length B	Height C	Diameter D	Length L	Unladen kg	Litres
5000 TRI-SR	710/50 R26.5	Rear	3 x 150	420 x 180	Yes	11000	2800	8750	3450	2133 (84")	6160	7750	22500
5500 TRI-SR	710/50 R26.5	Rear	3 x 150	420 x 180	Yes	11000	2800	9200	3450	2133 (84")	6410	7980	24750
6000 TRI-SR	710/50 R26.5	Rear	3 x 150	420 x 180	Yes	11000	2800	9750	3450	2133 (84")	6660	8250	27000

Please note that brand of tyre supplied may vary according to availability at time of manufacture.

TECHNICAL

TRAIL-S Trailing Shoe

Standard specification includes:

HiSpec distributor, 40mm flexible hose, individual sprung steel legs c/w toughened couler, active ground pressure, long life rubber trailing boot, galvanised steel frame c/w folding ends, LED road-lights, quick release chassis mounted mast, integrated stonetrap, splashplate, 6" blanked fill points (x2), electric divertor switch.

9 and 10.5 metre additional spec (hydraulic side incline suspension)



Folded 7.5 metre

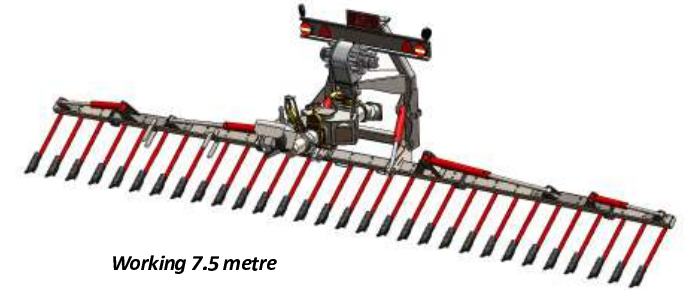

Working 7.5 metre

Model	Working Width	Outlets	Spacing	Distributor			Folding Ends	Transport Width	Hydraulic Incline Suspension	Control	Unladen kg	Galvanise
7.5 TRAIL-S	7.5 metres	30	25 cm	HiSpec			Yes	2550	N/A	2 Spools	850	Yes
9.0 TRAIL-S	9 metres	36	25 cm	HiSpec			Yes	2550	Yes	2 Spools	1000	Yes
10.5 TRAIL-S	10.5 metres	42	25 cm	HiSpec			Yes	2550	Yes	2 Spools	1150	Yes

D-B Dribble Bar

Standard specification includes:

HiSpec distributor, 40mm flexible hose, lay-flat hosing, break-back wings, galvanised frame, LED road-lights, quick release chassis mounted mast, integrated stonetrap, splashplate, 6" blanked fill points (x2), electric divertor switch.



Model	Working Width	Outlets	Spacing	Distributor			Folding Ends	Transport Width	Break Back Wings	Control	Unladen kg	Galvanise
7.5 D-B	7.5 metres	30	25 cm	HiSpec			No	2550	Yes, Springs	2 Spools	500	Yes
9.0 D-B	9 metres	36	25 cm	HiSpec			Yes	2550	Yes, Hydraulic	2 Spools	800	Yes
10.5 D-B	10.5 metres	42	25 cm	HiSpec			Yes	2550	Yes, Hydraulic	2 Spools	900	Yes

SALES

Your nearest HiSpec dealer is just a **click** away!!!

Visit www.hispec.net for dealer locations



CONTACT US



HiSpec Engineering Ltd
Station Road
Bagenalstown
Co. Carlow
R21 E038
Ireland



+353 (0) 59 97 21929



www.hispec.net
sales@hispec.net



WE ALSO DO.....





Too much to take in.....

Scan the QR code for viewing later on your device



Authorised Dealer Stamp

www.hispec.net

HiSpec believes the specification in this brochure to be correct at the time of printing. However, specifications, standard equipment and options are subject to change without notice.

Some equipment may be unavailable at time of manufacture. Please ask your dealer for advice concerning current availability of standard and optional equipment, and your dealer will verify that your tanker will include the equipment you ordered.

All images in this brochure may be shown with optional equipment.